

EP107

PRODUCT INFORMATION

The GYRO EP107 is an extremely useful commercial pillar with many applications. It has a smaller profile and fuse carrying capacity in comparison to our EP106.

MAXIMUM FUSE CAPACITY

- 32 x 63A
- Multiple 63A fuse carriers with 160A 3ph Din
- Multiple 63A fuse carriers with 2 x 250A Din
- 1 x 450A Din

FEATURES

- LID SCREWS: 4 x M8x16mm Button Head, Stainless Steel Screws, 5mm Drive or Tox Screws (to meet network requirements)
- Fitted with a 10-way neutral and rubber apron for maximum technical safety
- 13-way staggered neutral available on request

Optional Features

- Fuse carriers/disconnects fitted to your network requirements
- Lock, asset tag or alternate screws fitted to suit your network requirements



PRODUCT SKU'S

SKU	PRODUCT	DESCRIPTION
201130	EP107 ASSEMBLY & NEUTRAL BAR - BLACK	Assembly – Black Lid
201135	EP107 ASSEMBLY & NEUTRAL BAR - KHAKI	Assembly – Khaki Lid
201133	EP107 ASSEMBLY & NEUTRAL BAR - MARLBOROUGH SPEC	Assembly – Marlborough Spec
201137	EP107 ASSEMBLY & NEUTRAL BAR - AURORA SPEC	Assembly – Aurora Spec
201132	EP107 LID ONLY - BLACK	Lid Only - Black (no fittings)
201134	EP107 LID ONLY - KHAKI	Lid Only - Khaki (no fittings)
201136	EP107 LID ONLY - AURORA	Lid Only - Aurora (no fittings)
201131	EP107 BASE - BLACK	Base Only

EP107

PRODUCT INFORMATION

2-DIMENSIONAL DRAWINGS

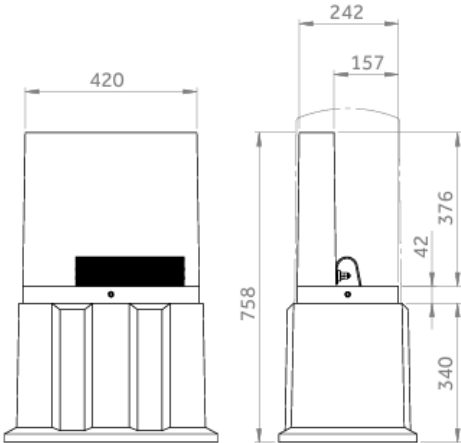
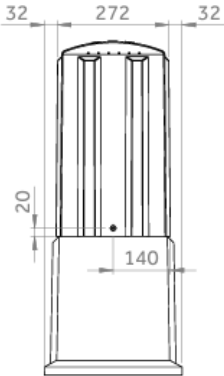
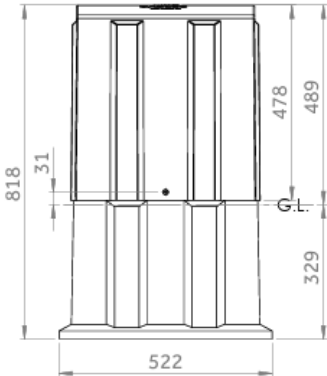
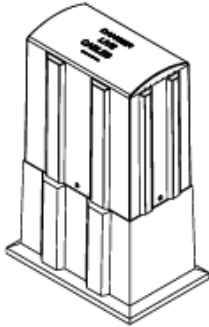
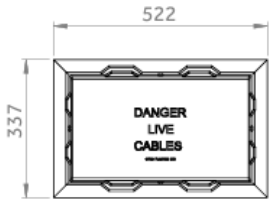

FUSE MOUNTING AREA
MAXIMUM CAPACITY 32x FUSES